

# 6 Lighting

## 6.1

### Overview

#### 6.1.1

##### Introduction and Scope

This chapter is a one-stop place where a builder, contractor, or lighting designer can get the information they need about residential lighting in low-rise buildings and in the dwelling units of high-rise buildings.

For residential buildings, all of the lighting requirements are mandatory measures. Therefore, lighting energy is not part of the energy budget for the whole building performance method, except as part of the standard assumption on internal heat gains that is assumed to be the same for all buildings. There are no tradeoffs between lighting and other building features.

The lighting requirements apply to alterations and additions (including replacements) as well as newly-constructed buildings. All new luminaires that are permanently installed must meet the requirements of §150(k), but existing luminaires may stay in place.

#### 6.1.2

##### Summary of the Residential Lighting Standards

The Residential Lighting Standards apply only to permanently installed luminaires, i.e., luminaires that are attached to the house, as opposed to portable luminaires such as torchieres or table lamps that are provided by the occupant. Permanently installed luminaires include ceiling luminaires, chandeliers, vanity lamps, wall sconces, under-cabinet luminaires, and any other type of luminaire that is attached to the house. Permanently installed luminaires may include hard wired or plug-in luminaires. See Section 6.2.6 below for additional information about permanently installed luminaires.

Each permanently installed luminaire is affected by the Standards and must be classified as either high efficacy or low efficacy. See Sections 6.2.1 and 6.2.2 for additional information about high efficacy and low efficacy luminaires.

The installed wattage of permanently installed luminaires must be considered only in kitchens. For each room or area, the requirements may be summarized as follows:

- **Kitchens.** At least half the installed wattage of luminaires in kitchens shall be high efficacy. However, some lighting installed inside a cabinet may not be included in the wattage calculation that determines half of the installed wattage is high efficacy. See Section 6.4 for information about residential kitchen lighting requirements.
- **Bathrooms, Garages, Laundry Rooms, Closets and Utility Rooms.** All luminaires shall either be high efficacy or shall be controlled by a vacancy sensor. Closets that are less than 70 ft<sup>2</sup> are exempt from this requirement. See Section 6.5 for information about residential lighting requirements in these rooms.
- **Other Rooms.** This applies only to rooms that are not kitchens, bathrooms, garages, laundry rooms, closets, or utility rooms. All installed luminaires shall either be high efficacy or shall be controlled by a vacancy sensor or dimmer. See Section 6.6 for information about residential lighting requirements in these rooms.
- **Outdoor Lighting.** All luminaires mounted to the building or to other buildings on the same lot shall be high efficacy luminaires or shall be controlled by a motion sensor in combination with a photocontrol, astronomical time clock, or energy management control system (EMCS). See Section 6.7 for information on residential outdoor lighting requirements.

- **Interior Common Areas of Multifamily Buildings.** All interior luminaires in the common areas of multifamily buildings shall either be high efficacy or shall be controlled by an occupant sensor. See Section 6.9 for information about residential lighting requirements for interior common areas of multifamily buildings.

The Residential Lighting Standards also have requirements for electronic ballasts (Section 6.2.5), permanently installed night lights (Section 6.2.7), lighting integral to exhaust fans (Section 6.2.8), and lighting switching requirements (Section 6.3).

Luminaires that are recessed into insulated ceilings are required to be rated for insulation contact (“IC-rated”) so that insulation can be placed over them. The housing of the luminaire shall be airtight to prevent conditioned air escaping into the ceiling cavity or attic, or unconditioned air infiltrating from the ceiling or attic into the conditioned space. See Section 6.10 below for additional information on luminaires recessed into insulated ceilings.

An additional set of requirements apply to parking lots or garages with space for eight or more cars, which are typically for multifamily buildings. The Nonresidential Lighting Standards for parking lots and/or garages apply in these cases (§132, §147). See Section 6.8 for additional information about Residential Lighting Standards for parking lots or garages with space for eight or more cars.

### **6.1.3**

#### **High-Rise Residential Dwelling Units and Hotel/Motel Guest Rooms**

§130(b) and (c)

The Residential Lighting Standards apply to dwelling units in high-rise residential and hotel/motel guest rooms as follows:

The design and installation of all lighting systems, lighting controls and equipment in high-rise residential dwelling units and in hotel/motel guest rooms shall comply with the applicable provisions of §150(k).

Indoor lighting in high-rise residential lighting and hotel/motel buildings for areas which are not in dwelling units must comply with the applicable Nonresidential Indoor Lighting Standards. See Section 1.7.4 of the Nonresidential Compliance Manual for additional information on mixed use buildings.

Outdoor lighting that is permanently attached to the building, and is separately controlled from the inside of a high-rise residential dwelling unit or guest room shall comply with the applicable requirements of §150(k).

Outdoor lighting that is permanently attached to the building, but is not separately controlled from inside of a high-rise residential dwelling unit or guest room shall comply with the applicable Nonresidential Outdoor Lighting Standards.

Signs that are not inside the dwelling units of high-rise residential living quarters and in hotel/motel guest rooms shall comply with the applicable Sign Lighting Standards in §133 and §148.

### **6.1.4**

#### **Fire Stations**

Many fire stations are mixed use buildings, having some function areas that are clearly nonresidential and other function areas that are clearly used for staff housing. The staff housing areas may be occupied 24 hours per day, except when staff is out on an emergency call. The nonresidential function areas are required to meet the applicable Nonresidential Lighting Standards. The staff housing areas shall comply with the applicable provisions of §150(k).

### **6.1.5**

#### **Related Documents**

There are a number of publications and documents available from the California Energy Commission and others that provide additional information about residential lighting. A summary of these is listed below:

- The Nonresidential Manual should be consulted for more details on the requirements for parking lots and parking garages.
- The Residential Lighting Design Guide, (Best practices and lighting designs to help buildings comply with California's 2005 Title 24 energy code) is available from the California Lighting Technology Center ([www.CLTC.ucdavis.edu](http://www.CLTC.ucdavis.edu)). While this document is written for the 2005 Standards, much of the information is still relevant for the 2008 Residential Lighting Standards.
- The Advanced Lighting Guidelines, available from the New Buildings Institute ([www.newbuildings.org](http://www.newbuildings.org)) is an informative resource for energy efficient lighting design, luminaires, and controls. While the document is mostly oriented for nonresidential lighting applications, it has generic information about lamps, ballasts, luminaires, and controls that is applicable to low-rise residential buildings.
- Professionally qualified lighting designers can be quickly located via the websites of the International Association of Lighting Designers ([www.iald.org/index](http://www.iald.org/index)), or the National Council on Qualifications for the Lighting Professions (NCQLP): [www.ncqlp.org](http://www.ncqlp.org). Many designers are ready to offer informal advice as well as undertake commissioned work.
- Many books on residential lighting design are available. The best books explain the principles of good lighting design as well as showing examples of luminaires. The fast pace of lamp development makes recently written books much more useful.
- Guidance on the selection and use of lighting technologies is available from the Lighting Research Center's National Lighting Product Information Program, at [www.lrc.rpi.edu/programs/nlpip](http://www.lrc.rpi.edu/programs/nlpip). Additional resources for energy efficient lighting and other building systems are available from the California Building Industry Institute at [www.thebii.org](http://www.thebii.org).

## 6.2

### Luminaires

A luminaire is the lighting industry's term for light fixture. A luminaire consists of the housing, power supply (including ballast or transformer), lamp, reflector, and in some cases a lens. A lamp is the lighting industry's term for a light bulb. Luminaires can be designed to be recessed into the ceiling, suspended by a rod, cable, or chain, surface mounted on the wall or ceiling, or attached to a cabinet. Portable table and floor lamps are also classified as luminaires, but they are not covered by the Residential Lighting Standards. Every installed luminaire shall be classified as either high efficacy or low efficacy for compliance with the Residential Lighting Standards. The rules for classifying a luminaire as high efficacy are explained further in Sections 6.2.1 and 6.2.3.

#### 6.2.1

### High Efficacy Luminaires

§150(k)1

**High Efficacy Luminaire.** A high efficacy luminaire is one that meets the efficacies listed in Table 150-C of the Standards (shown as Table 6-1 and Table 6-2 in this chapter), contains only high efficacy lamps or high efficacy LED lighting, and must not contain a socket which allows any low efficacy lighting system to be used. For example, any luminaire containing a medium screw base socket is classified as low efficacy, regardless of the type of lamp installed into that socket.

Typically, high efficacy luminaires contain pin-based sockets, like compact fluorescent or linear fluorescent lamp sockets, though other socket types such as screw sockets specifically rated only for high intensity discharge lamps (like metal halide lamps) light

emitting diode (LED) luminaires (dedicated LED lighting fixtures that cannot use incandescent or any other type of lighting technology) may also qualify as high efficacy. Additional information about qualifying HID luminaires or LED lighting as high efficacy is discussed below.

**High Intensity Discharge (HID)** lighting is primarily used in nonresidential applications. It is most often used for street, parking lot, indoor warehouse, and retail display lighting. When HID lighting is used for residential applications, it is typically used outdoors. Two types of HID lighting are high pressure sodium, which gives off an amber color light, and metal halide, which gives off a cool white light. The Residential Lighting Standards do not disallow HID lighting to be used indoors, but this technology is typically considered too bright for residential indoor use, and currently, the technology requires significant warm up time before reaching full light output.

Exception 1 to §150(k)2A

HID luminaires containing factory installed ballasts and HID rated medium screw base sockets may be classified as high efficacy luminaires provided they meet the efficacies listed in Table 150-C of the Standards (shown as Table 6-1 and Table 6-2 in this chapter).

Exception 1 to §150(k)1

An HID luminaire rated for use only with a HID reflector lamp shall have a minimum lamp efficacy within 2 lumens per watt of the minimum lamp efficacies in Table 150-C.

**Induction Lighting** combines induction and gas discharge lighting technologies, mostly used as an alternative to outdoor HID lamps. Induction lamps do not contain electrodes, and the lighting system is comprised of three components; a generator, power coupler, and the lamp. Induction lamps have relatively long lives.

**GU-24.** A relatively new type of line-voltage socket is the GU-24. The definition of GU-24 is in §101. Compact fluorescent lamps and LED lamps have recently been introduced into the market with GU-24 bases.

Exception 2 to §150(k)2A

A luminaire with a line-voltage socket is classified as low efficacy according to the Residential Lighting Standards; however, there is an exception which allows luminaires with a GU-24 socket to qualify as high efficacy. A luminaire with a factory installed GU-24 lamp holder may be classified as high efficacy provided that it meets all of the following requirements:

1. The luminaire is not a recessed downlight rated to be used with a compact fluorescent lamp; and
2. The luminaire does not contain any other type of line-voltage socket or lamp holder (for example, the luminaire cannot use any screw-based lamps, including screw-based incandescent, screw-based fluorescent, or screw-based LED lamps); and
3. The manufacturer does not make available adaptors or other modular components for the luminaire which will convert the GU-24 lamp holder to any other type of socket or lamp holder; and
4. The luminaire is rated for use only with high efficacy lamps or a high efficacy LED lighting source system, according to Table 150-C of the Standards (shown as Table 6-1 and Table 6-2 of this chapter).

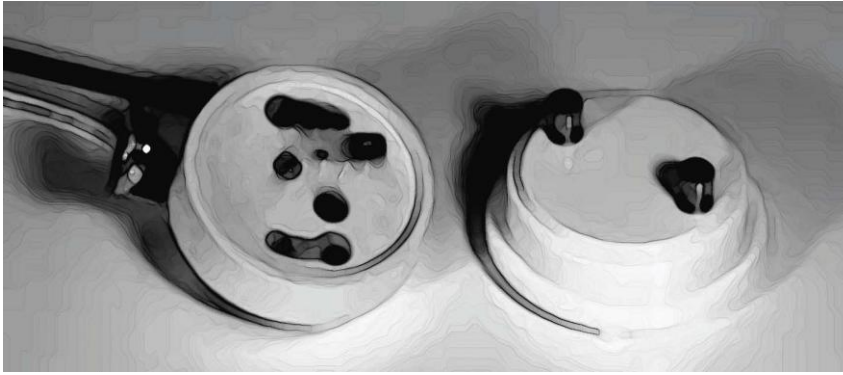

Figure 6-1 – GU-24 socket and base

§119(m); Table 150(c)

**LED Certification Requirements.** Light emitting diode (LED) lighting may qualify as either high efficacy or low efficacy. To qualify as high efficacy, an LED lighting source system, including fully integrated LED luminaires and LED trims, must be certified to the Energy Commission. Additional information about certifying LED luminaires to the Energy Commission is in Section 6.2.9. For additional information about LED lighting see Section 6.2.10.

§130(d); §150(k)1; Table 150-C

**High Efficacy LED Trims.** The two most common types of LED lighting available today are fully integrated LED luminaires, and LED “trims.” There are also a few screw-based and pin-based LED lamps (bulbs) available, such as PAR and BR style LED lamps, as well as MR-16 style LED lamps. However, because these LED screw-based and pin-based lamps are interchangeable with low efficacy lamps, they do not qualify a luminaire as high efficacy for compliance with the Residential Lighting Standards.

An LED trim is a one-piece integral unit containing the power supply, transformer, heat sink, and LED circuit board, which is designed to be installed into recessed luminaire housings.

Many manufacturers of LED trims do not manufacture their own luminaire housing, but rather install their LED trims into luminaire housings manufactured by another company. These third-party luminaire housings are typically classified as low efficacy according to Residential Lighting Standards.

Following is an alternate method, approved in accordance with §130(d), for determining the wattage of LED trims. This method for classifying LED trims as high efficacy applies only to LED trims, and shall not be applied to determining wattage for compact fluorescent or other lighting technologies.

The installation of an LED trim may be classified as a high efficacy luminaire provided that all of the following conditions are met:

1. The LED trim shall be certified to the Energy Commission as high efficacy according to Table 150-C of the Standards (shown as Table 6-1 and Table 6-2 of this chapter). Additional information about certifying LED lighting as high efficacy is in Section 6.2.9; and
2. The LED trim shall be hardwired directly to the luminaire housing. The wiring assembly may include a mid-line connector between the LED trim and the wire ends. The mid-line connector may be a GU-24, or other type of connector, but it shall not include a screw-base socket configuration; and
3. The luminaire housing shall not contain a screw-base socket; and
4. Screw-base adaptors shall not be used, even if the manufacturer considers them to be

“permanent”; and

5. If the LED trim provided by the manufacturer has a screw-base attached to the end of a “pig-tail”, the screw-base must be cut off and discarded prior to hard wiring the trim directly into the luminaire housing. However, check any UL restrictions on such modifications.

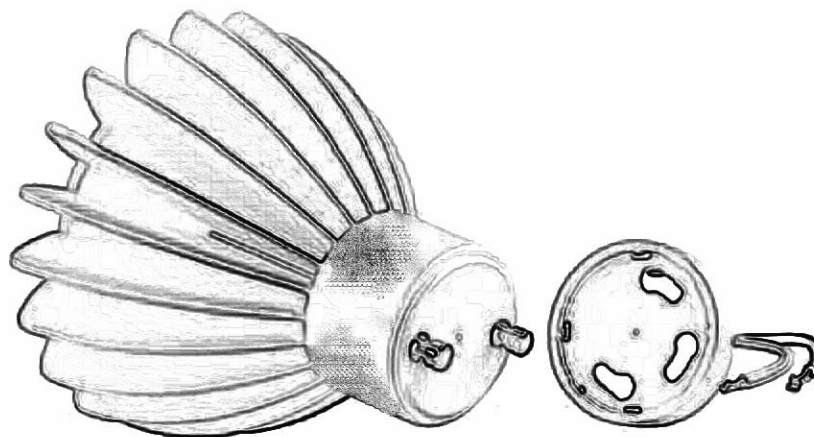

Figure 6-2 – One type of LED trim with GU-24 base

§101 definitions

**Hybrid LED Luminaire.** A hybrid LED luminaire contains an LED source system as well as another type of light sources, such as incandescent or fluorescent lighting system. A hybrid LED luminaire is defined as a complete lighting unit consisting of a light source and driver together with parts to distribute light, to position and protect the light source, and to connect the light source to a branch circuit. The hybrid LED luminaire is intended to be connected directly to a branch circuit.

§150(k)1; Table 150-C

When an LED source system has been certified to the Energy Commission as high efficacy, and the other light source in the hybrid luminaire also qualifies as high efficacy according to Table 150-C of the Standards (shown as Table 6-1 and Table 6-2 of this chapter), the entire luminaire may be classified as high efficacy for compliance with the Residential Lighting Standards.

Exception 2 to §150(k)1

However, when a high efficacy LED source system is combined with a low efficacy lighting system in a Hybrid LED Luminaire, the high efficacy and low efficacy lighting systems shall each separately comply with the applicable requirements of §150(k).

§119(n)

**Ballast for Recessed Luminaire Certification Requirements.** Ballasts for a compact fluorescent lamp installed in a residential recessed luminaire shall be certified to the Energy Commission. Ballasts which have not been certified to the Energy Commission shall not be used in residential recessed luminaires. Additional information about certifying to the Energy Commission is in Section 6.2.9.

## 6.2.2

### Low Efficacy Luminaires

§150(k)2

A low efficacy luminaire is any luminaire that does not qualify as high efficacy; or any of

the following lighting systems, regardless of efficacy:

1. Contains any type of line-voltage socket or lamp holder, including conventional medium screw-base sockets, candelabra sockets, pin-based sockets, or any other type of line-voltage lamp holders capable of accepting an incandescent lamp or any other type of low efficacy lamp. However, under certain conditions (described in Section 6.2.1) a luminaire with a GU-24 line-voltage socket may be classified as high efficacy.
2. Low voltage incandescent lighting.
3. Track lighting of any type, or any other lighting systems which allows the addition or relocation of luminaires without altering the wiring of the system.
4. Lighting systems which have modular components that allow conversion between screw-based and pin-based sockets without changing the luminaires' housing or wiring.
5. Electrical boxes that are finished with a blank cover, or electrical boxes where no electrical equipment has been installed, where the electrical box can be used for a luminaire or a surface mounted ceiling fan.
6. LED lighting which has not been certified to the Energy Commission as high efficacy.

### **6.2.3**

#### **Qualifying a Lighting System as High Efficacy**

“Lumens per watt” for lighting is analogous to “miles per gallon” for an automobile. The lumen is the unit of visible light. To be rated as high efficacy, a lamp must produce a certain number of lumens for each watt of electrical power it consumes. Efficacy is therefore measured in lumens per watt. The following lighting systems typically qualify as high efficacy light sources:

1. Fluorescent lamps equipped with electronic ballasts
2. LED lighting which has been certified to the Energy Commission as high efficacy
3. Metal halide lighting (a type of HID lamp)
4. High Pressure Sodium (a type of HID lamp)
5. Low Pressure Sodium (however, this technology is not recommended for use in residential applications. It is not often used anymore in any application because it has the worst color rendering of any light source, having a deep yellow color)
6. Induction Lighting

The following lighting systems do not qualify as high efficacy lighting systems:

1. Incandescent lamps of any type (including any screw-in incandescent lamps, like regular ‘A’ or reflector lamps, or quartz halogen lamps, or low voltage lamps, like halogen MR lamps).
2. Mercury vapor lamps (a type of HID lamp) To be classified as high efficacy, a lamp or lighting system must meet the requirements listed in Table 150-C of the Standards. For clarity, Table 150-C of the Standards is shown below as two different tables. It is shown as Table 6-1 for all lighting systems which are not LED lighting, and it is shown again as Table 6-2 for all LED lighting.

#### **Lighting Other Than LED**

§150(k)1; Table 150-C

For any lighting systems which are not LED lighting, simply divide the initial rated lumens of the lamp by the rated watts of the lamp. Lamp lumens can typically be found on the lamp package or in a manufacturer’s catalogue. This calculation method should be used for any lighting system which is not LED lighting, including the following types of lighting systems:

1. Line-voltage incandescent
2. Low-voltage incandescent
3. Fluorescent
4. High intensity discharge (HID)
5. Induction

For simplicity, for non-LED lighting, the power used by the ballast or transformer is ignored when determining the lumens per watt for purposes of classifying lighting systems as high efficacy for compliance with the Residential Lighting Standards.

However, when determining how many watts of high and low efficacy lighting is being installed in residential kitchens, the power used by the ballast or transformer is included. Additional information about determining installed lighting power in residential kitchens is in Section 6.2.4.

A high efficacy luminaire, for all lighting systems which are not LED lighting, shall meet the minimum lamp efficacy requirements in Table 6-1 (which is Table 150-C in the Standards).

Table 6-1 – High Efficacy Lamps – Other Than LED Lighting

Lamp Power	Minimum Lamp Efficacy
5 W or less	30 lm/W
over 5 W to 15 W	40 lm/W
over 15 W to 40 W	50 lm/W
over 40 W	60 lm/W

### LED Lighting

§119(m); Table 150(c)

An LED Luminaire, or LED Light Engine with Integral Heat Sink, shall be certified to the Energy Commission before it can be classified as high efficacy for compliance with the Residential Lighting Standards. Any LED lighting system which has not been certified to the Energy Commission as high efficacy shall be classified as a low-efficacy lighting system. Additional information about certifying to the Energy Commission is in Section 6.2.9.

LED wattage, luminous flux, and efficacy must be determined according to Reference Joint Appendix JA8 (JA8), or to IES LM-79-08. See Section 6.2.10 for additional information about testing LED lighting.

§130(d)5 clarifies that the input power for LED lighting shall be the maximum rated input wattage of the system, including power used by fans, transformers and power supply devices. The maximum rated input wattage shall be listed on a permanent, pre-printed, factory-installed label.

A high efficacy LED luminaire or high efficacy LED source system shall meet the minimum system efficacy requirements in Table 6-2 (which is Table 150-C in the Standards).

For a Hybrid LED Luminaire to qualify as high efficacy, the LED Light Engine with Integral Heat Sink shall meet the minimum system efficacy requirements in Table 6-2, shall be certified to the Energy Commission as high efficacy, and all other lighting systems in the luminaire shall meet the minimum lamp requirements in Table 6-1 (which is Table 150-C in the Standards).



The Standards require that the maximum rated input wattage shall be listed on a permanent, pre-printed, factory-installed label as specified by Underwriters Laboratories (UL). However, there's a new LED lighting system recently introduced, where a centrally located driver is being used to operate more than one luminaire. Therefore, when multiple luminaires are connected to a single power supply/driver, the label used to determine the maximum wattage of the LED system shall be located on the LED power supply/driver, and the wattage of the system shall be based on the connected load of that LED power supply/driver as determined by the luminaire manufacturer or the rating of that LED power supply/driver as determined by the manufacturer of the power supply/driver.

Table 6-2– High Efficacy LED Lighting Source Systems

System Power Rating for LED Lighting	Minimum System Efficacy for LED Lighting
5 W or less	30 lm/W
over 5 W to 15 W	40 lm/W
over 15 W to 40 W	50 lm/W
over 40 W	60 lm/W

**6.2.4  
Kitchen Luminaire Input Power**

§150(k)3; §150(k)8

The Residential Lighting Standards require luminaire input power (wattage) to be determined in kitchens. Energy used by ballasts, transformers, and power supplies is included when determining installed lighting power.

§150(k)3

**Blank Electrical Boxes**

In residential kitchens, the wattage of electrical boxes finished with a blank cover or where no electrical equipment has been installed, and where the electrical box can be used for a luminaire or a surface mounted ceiling fan, shall be calculated as 180 watts of low efficacy lighting per electrical box.

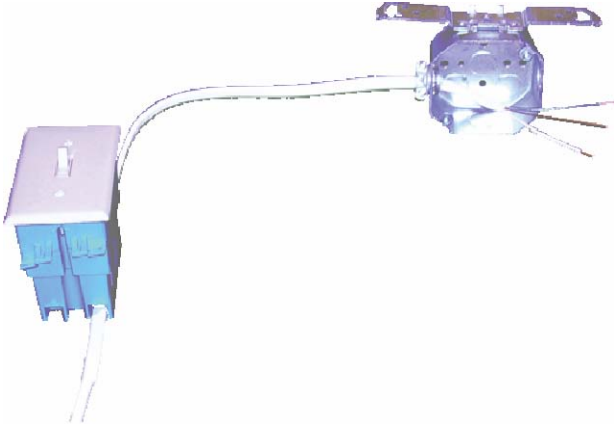

Figure 6-3 – Blank Electrical Box

**Input Power Determined According to Type of Luminaire**

The following requirements for determining how much wattage is installed in residential kitchens are in §130(d).

### **Line Voltage Sockets**

§130(d)1

The wattage of a luminaire with a line-voltage socket is determined by the rating of the luminaire, as described below, and not by the wattage of the initial lamp (light bulb) that is installed in the luminaire. A medium screw-base socket, which is a type of line-voltage socket, can accommodate a variety of different lamp technologies, including general service incandescent, halogen, reflector, and compact fluorescent, ranging in wattages from 2-1/2 to 250W. Line-voltage sockets include a variety of screw, pin, and bayonet bases, for which there is no transformer, ballast, or power supply between the wires connected to the luminaire and the lamp.

### **No Peel-off or Peel-down Wattage Labels**

For line-voltage luminaires, the relamping rated wattage of the luminaire shall be listed on a permanent, pre-printed, factory-installed label, as specified by UL 1598. The factory-installed wattage label shall not consist of peel-off or peel-down layers or other methods which allow the rated wattage to be changed after the luminaire has been shipped from the manufacturer.

However, this disallowance of peel-off labels does not apply to IC and non-IC peel-off labels intended to be removed in the field as indicated in the luminaire manufacturer's installation instructions, provided that UL 1598 and applicable electrical codes are adhered to.

### **Recessed Versus Non-recessed Line-voltage Luminaires**

There are different requirements for determining the wattage of recessed luminaires than there are for determining the wattage of luminaires which are not recessed, as follows:

Luminaires Which Are Not Recessed – including surface, pendant, pole, and under-cabinet mounted luminaires, shall be the maximum relamping rated wattage of the luminaire, as listed on a permanent, pre-printed, factory-installed label, as specified by UL 1598. The factory-installed wattage label shall not consist of peel-off or peel-down layers or other methods which allow the rated wattage to be changed after the luminaire has been shipped from the manufacturer.

Luminaires Which Are Recessed – shall be the larger of 1 or 2 below:

1. The maximum relamping rated wattage of the recessed luminaire, as listed on a permanent, pre-printed, factory-installed label, as specified by UL 1598, or
2. If the relamping rated wattage is smaller than the wattages listed below, then the wattages listed below must be used. The wattage is determined by the diameter and mounting height of the luminaire, as follows.
  - a. 50W per socket for luminaires with housings or trims with an aperture diameter less than 5 inches (125 mm) regardless of mounting height; or
  - b. 50W per socket for luminaires with housings or trims with an aperture diameter of greater than or equal to 5 inches (125 mm) and a mounting height of 11 ft or less; or
  - c. 60W per socket for luminaires with housings or trims with an aperture diameter of greater than or equal to 5 inches (125 mm) and a mounting height of greater than 11 feet but less than 15 ft; or
  - d. 75W per socket for luminaires with housings or trims with an aperture diameter of greater than or equal to 5 inches (125 mm) and a mounting height of 15 ft or more.

For clarity, Table 6-3 shows the above information in a table.

Table 6-3 –Recessed Luminaire with Line voltage Lamp Holders

Input wattage per socket shall be larger of what is listed on the UL label, or the wattage listed below, depending on the aperture and mounting height of the luminaire.

		Recessed Luminaire Aperture							
		≤3"	4"	5"	6"	7"	8"	9"	≥10"
Mounting Height	≤ 8'	50W	50W	50W	50W	50W	50W	50W	50W
	9'	50W	50W	50W	50W	50W	50W	50W	50W
	10'	50W	50W	50W	50W	50W	50W	50W	50W
	11'	50W	50W	50W	50W	50W	50W	50W	50W
	>11'	50W	50W	60W	60W	60W	60W	60W	60W
	13'	50W	50W	60W	60W	60W	60W	60W	60W
	<15'	50W	50W	60W	60W	60W	60W	60W	60W
	15'	50W	50W	75W	75W	75W	75W	75W	75W
	≥16'	50W	50W	75W	75W	75W	75W	75W	75W

**Luminaires with Modular Components**

§130(d)1C

For luminaires designed to accommodate a variety of trims or modular components that allow the conversion between screw-based and pin-based sockets without changing the luminaire housing or wiring, the highest wattage designated by the correlated marking on a permanent, pre-printed, factory-installed label on the luminaire housing shall be used.

**Luminaires with Ballasts**

§130(d)2

Includes fluorescent, induction, and HID luminaires

The wattage of luminaires with permanently installed or remotely installed ballasts shall be the operating input wattage of the rated lamp/ballast combination published in manufacturer’s catalogs based on independent testing lab reports as specified by UL 1598.

The wattage of a compact fluorescent or high intensity discharge luminaire that can accommodate a range of wattages without changing the luminaire housing, ballast, or wiring shall be the larger of the installed wattage, or the average wattage of the lamp/ballast combinations for which the luminaire is rated.

For example, a compact fluorescent luminaire which is rated for use with 26, 32, and 42W compact fluorescent lamps without changing the luminaire housing, ballast or wiring is determined by adding all three wattages together (26 + 32 + 42 = 100) and divide that total by 3 (100/3 = 33.33W). Luminaire wattage shall then be determined according to the wattage of the lamp initially installed as shown below in Table 6-4:

Table 6-4 –Multi-wattage Ballasts

Initial Lamp Wattage Installed	Installed Wattage Shall Be
26W	33.33W
32W	33.33W
42W	42W

### Line-Voltage Track Lighting

§130(d)3

For versatility, there are a number of different options for determining the wattage of line-voltage lighting track or busway. See §130(d)3 or Section 5.4.3 of the Nonresidential Compliance Manual for additional information on determining input power for line-voltage track lighting.

A summary of the four options available for determining the power of line-voltage track is as follows:

1. The VA rating of the branch circuit feeding the track, or
2. The higher of:
  - a. The rated wattage of all of the luminaires included in the system, or
  - b. 45W per linear foot of track, or
3. If using an integral current limiter which has been certified to the Energy Commission, the higher of:
  - a. The VA of the integral current limiter, or
  - b. 12.5W per linear foot of track, or
4. If using a dedicated track lighting supplementary over current protection panel, the sum of the ampere (A) rating of all of the over current protection devices times the branch circuit voltages. A supplementary over current protection panels is typically used in nonresidential applications and may not be practical for use in residential applications.

### Low-voltage Lighting

§130(d)4

This method for determining luminaire power applies to any low-voltage lighting system having a transformer, including low-voltage track lighting, or individual low-voltage luminaires.

The wattage of luminaires or lighting systems with permanently installed or remotely installed transformers shall be determined as follows:

1. The rated wattage of the lamp/transformer combination, listed on a permanent, pre-printed, factory-installed label, as specified by UL, and
2. For luminaires with transformers rated greater than 53W, the factory-installed wattage label shall not consist of peel-off or peel-down layers or other methods which allow the rated wattage to be changed after the luminaire or lighting system has been shipped from the manufacturer.

### 3. LED Lighting Source System

§130(d)5

LED lighting source systems shall be the maximum rated input wattage of the system as defined in §101. LED lighting system wattage shall be tested in accordance with Reference Joint Appendix JA8 or IES LM-79-08. The maximum rated input wattage shall be listed on a permanent, pre-printed, factory-installed label as specified by Underwriters

Laboratories (UL). Additional information about testing LED lighting is in Section 6.2.10.

### **Miscellaneous Lighting Systems**

§130(d)6

This method applies only to lighting systems which have not already been addressed by another subsection of §130(d), and is primarily intended to address new technologies. This method shall not be applied to incandescent, fluorescent, HID, or LED luminaires because these lighting technologies are already addressed in different subsections of §130(d).

The wattage of all other miscellaneous lighting equipment shall be the maximum rated wattage of the lighting equipment, or operating input wattage of the system, listed on a permanent, pre-printed, factory-installed label, or published in manufacturer's catalogs, based on independent testing lab reports as specified by UL 1574 or UL 1598.

### **GU-24 Lamps, Luminaires, and Adaptors**

§130(e)

GU-24 Lamps, Luminaires, and Adaptors installed in California shall meet the following requirements:

1. Lamps with GU-24 bases shall have a minimum efficacy no lower than specified in Table 150-C (shown as Table 6-1 and Table 6-2 in this chapter).
2. The wattage of luminaires with GU-24 sockets shall be the operating input wattage as listed on a permanent, pre-printed, factory-installed label on the luminaire housing, as specified by UL. Luminaires with GU-24 sockets shall not be rated for any lighting system that has an efficacy lower than specified in Table 150-C.
3. Luminaires with GU-24 sockets shall not have modular components allowing conversion to any lighting system that has an efficacy lower than specified in Table 150-C.
4. There shall be no adaptors that convert a GU-24 socket to any other type of lighting system that has an efficacy lower than specified in Table 150-C.

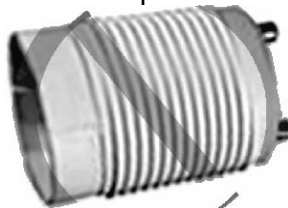

Figure 6-4 – GU-24 to medium screw base adaptor shall not be used

Note: Compact fluorescent ballast that has a GU-24 base on one end, and a compact fluorescent lamp socket on the other end, is not considered an adaptor. It is considered an integral component of a high efficacy lighting system.

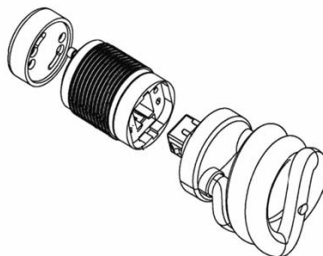

Figure 6-5 – Compact fluorescent ballast is not considered an adaptor

## NO “Permanent” Adaptors

The Standards do not recognize any adaptor as being able to permanently converting one type of luminaire to another type for compliance with the Standards. For example, there are no “permanent” adaptors for converting a luminaire with incandescent screw-base socket to a permanently installed compact fluorescent luminaire, regardless of manufacturer declarations.



Figure 6-6 – A medium screw base to GU-24 socket adaptor is not recognized as high efficacy by Title 24.

### 6.2.5

#### Electronic Ballasts

§150(k)4

Fluorescent lamps with a power rating of 13 W or more shall have an electronic ballast that operates the lamp at a frequency of 20 kHz or more. All commonly available electronic ballasts meet this requirement.

Luminaires with high intensity discharge (HID) lamps (like pulse-start metal halide or high-pressure sodium) may contain hardwired electromagnetic HID ballasts.

Pin based compact fluorescent lamps that are operated with electronic ballasts typically have four-pin lamp holders. Pin-based compact fluorescent lamps with two-pin lamp holders typically will indicate that the ballast is magnetic.

However, the above rule-of-thumb, where a two-pin lamp holder typically indicates that a magnetic ballast is being used, does not apply to lamps having a GU-24 base. GU-24 sockets are line-voltage sockets in which there is not a ballast between the socket and the lamp. Therefore, the ballast is integral to the lamp. To determine if an integral compact fluorescent lamp with a GU-24 base has an electronic ballast, the label on the lamp will need to be checked.

§119(n)

There are also requirements for compact fluorescent ballasts in recessed luminaires to be certified to the Energy Commission. See Section 6.2.9 for additional information.

### 6.2.6

#### Permanently Installed and Portable Luminaires

The Residential Lighting Standards require that all permanently installed luminaires be high efficacy as defined in §150(k)1, with some exceptions described later in this chapter. The Residential Lighting Standards do not apply to portable luminaires.

§101 definitions

Permanently installed luminaires include all luminaires attached to the inside or outside of a building or site. Permanently installed luminaires may have either plug-in or hardwired connections for electric power. This includes plug-in under-cabinet lighting where the luminaires are attached to the bottom of the cabinets. Permanently installed luminaires include the following:

1. Lighting attached to walls, ceilings, columns.
2. Track and flexible lighting systems.
3. Lighting inside permanently installed cabinets.
4. Lighting attached to the top or bottom of permanently installed cabinets.
5. Lighting attached to ceiling fans.
6. Lighting integral to exhaust fans.
7. Lighting that is integral to garage door openers if it is designed to be used as general lighting, is switched independently from the garage door opener, and does not automatically turn off after a pre-determined amount of time.

Permanently installed lighting does not include:

1. Portable lighting as defined by §101.
2. Lighting installed by the manufacturer in refrigerators, stoves, microwave ovens, exhaust hoods for cooking equipment, refrigerated cases, vending machines, food preparation equipment, and scientific and industrial equipment.
3. Lighting in garage door openers which consists of no more than two screw-based sockets integrated into the garage door opener by the manufacturer, where the lights automatically turn on when the garage door is activated, and automatically turn off after a pre-determined amount of time.

The definition of permanently installed lighting in §101 includes outdoor lighting mounted on poles, in trees, or in the ground. However, because outdoor lighting mounted on poles, in trees, or in the ground is not regulated by the Residential Lighting Standards, this portion of the definition applies only to nonresidential outdoor lighting applications.

Portable lighting, for residential applications, is defined as lighting with plug-in connections for electric power that is table and freestanding floor lamps. However, plug-in lighting attached to the bottom of a cabinet is considered permanently installed lighting.

### **6.2.7**

#### **Night Lights**

§150(k)5

Permanently installed night lights and night lights integral to a permanently installed luminaire or exhaust fan shall meet one of the following conditions:

1. Shall contain only high efficacy lamps meeting the minimum efficacies contained in Table 150-C of the Standards (shown as Table 6-1 and Table 6-2 of this chapter) and shall not contain a line-voltage socket or line-voltage lamp holder, or
2. Shall be rated to consume no more than 5W of power as determined by §130(d), and shall not contain a medium screw-base socket.

Note: Indicator lights that are integral to lighting controls shall comply with §119(b).

### **6.2.8**

#### **Lighting Integral to Exhaust Fans**

§150(k)6

Lighting integral to exhaust fans, in rooms other than kitchens, shall meet the applicable requirements of §150(k). This lighting integral to exhaust fans must be controlled separately from the exhaust fan according to §150(k)7 and as described further in Section 6.3.

### **6.2.9**

#### **Certification to the Energy Commission**

§100(k); §110; §119

Certification to the Energy Commission is completed by manufacturers of regulated devices. Certification includes a declaration of compliance, executed under penalty of perjury of the laws of California, that the regulated device meets the requirements of the Standards.

For compliance with the Title 20 Appliance Efficiency Regulations, and the Title 24 Building Energy Efficiency Standards, the Energy Commission maintains a database of appliances, controls, and other devices which have been certified to the Energy Commission.

For compliance with the Residential Lighting Standards, this database includes lighting controls, ballasts for residential recessed luminaires, and high efficacy LED lighting source systems.

Lighting controls, ballasts for residential recessed luminaires, and high efficacy LED lighting source systems shall not be installed unless they have been certified by the manufacturer and listed on this database. The database and certification instructions are available from the following web links:

[/www.energy.ca.gov/appliances/database/index.html](http://www.energy.ca.gov/appliances/database/index.html)

[www.energy.ca.gov/appliances/forms/](http://www.energy.ca.gov/appliances/forms/)

The certification for residential lighting applications includes the following:

1. **Lighting Controls.** Lighting controls must be certified to the Energy Commission as complying with the applicable provisions of §119. This includes vacancy sensors (manual on / automatic off occupancy sensors) and dimmers.
2. **High Efficacy LED Lighting Source Systems.** For a light emitting diode (LED) lighting source system to qualify as high efficacy, an LED Luminaire, or LED Light Engine with Integral Heat sink shall be certified to the Energy Commission as meeting all of the following conditions:

Shall meet the minimum efficacy requirements in Table 150-C (shown as Table 6-2 of this chapter)

Input power shall be determined as specified by §130(d)5.

The LED lighting source system shall be tested, by an independent testing lab, according to Reference Joint Appendix JA8 or according to IES LM-79-08. See Section 6.2.10 for more information about testing LED lighting.

3. **Ballasts for Residential Recessed Luminaires.** All ballast for use in a residential recessed luminaire shall be certified to the Energy Commission according to §119(n), as meeting the following conditions:
  - a. Be rated by the ballast manufacturer to have a minimum rated life of 30,000 hours when operated at or below a specified maximum case temperature. This maximum ballast case temperature specified by the ballast manufacturer shall not be exceeded when tested in accordance to UL 1598 Section 19.15; and
  - b. Have a ballast factor of not less than 0.90 for non-dimming ballasts and a ballast factor of not less than 0.85 for dimming ballasts.



## 6.2.10

### Light Emitting Diode (LED) Lighting Source Systems

LED lighting is now available for use in residential applications. For the foreseeable future, there will continue to be both high efficacy and low efficacy LED lighting available. To be classified as high efficacy for compliance with the Residential Lighting Standards, LEDs shall be certified to the Energy Commission. LED sources systems which are not certified to the Energy Commission shall be classified as low efficacy lighting in residential applications.

The Standards include the following language to address the use of LED lighting:

1. §101 contain definitions for LED lighting.
2. §119 require LED lighting to be certified to the Energy Commission before it can be classified as high efficacy for residential applications. An LED luminaire, or LED light engine with integral heat sink, shall be classified as low efficacy if it has not been certified to the Energy Commission as high efficacy. Additional information about certifying to the Energy Commission is in Section 6.2.9.
3. §130(d)5 points to Reference Joint Appendix JA8 for determining how much power (wattage) is installed with an LED lighting system. JA8 requires that wattage for LEDs shall be the maximum rated input wattage of the LED lighting system, including power used by fans, transformers, and power supply devices
4. §150(k)1 and Table 150-C (shown as Table 6-2 of this chapter) has requirements for determining when an LED lighting source system can be classified as high efficacy. Additional information about classifying high efficacy lighting is in Section 6.2.1.
5. Reference Joint Appendix JA8 is the required method for testing LED source systems, including testing for input power, luminous flux, and calculation of efficacy. The IES LM-79-08, Approved Method: Electrical and Photometric Measurements of Solid-State Lighting Products, is an alternate test method that can be used for determining luminous flux measurement of LED luminaires or LED light engines with integral heat sink, provided that wattage is determined in accordance with JA8.2, the testing lab is accredited in accordance with JA8.2c, and efficacy is calculated in accordance with JA8.4.
6. §101 defines an LED Light Engine with Integral Heat Sink (or LED Light Source System) as a subsystem of an LED Luminaire that includes one or more LED Components, LED Devices or LED Packages, an LED Array, or LED Module; an LED Driver (Power Source); electrical and mechanical interfaces; and an integral heat sink to provide thermal dissipation. An LED Source System may be designed to accept additional components that provide aesthetic, optical, and environmental control (other than thermal dissipation).
7. An LED Source System with standardized base is an LED Lamp. A standardized base is an ANSI standardized base (such as a medium screw-base socket) that is designed to connect to the branch circuit via an ANSI standardized lampholder/socket. For the purposes of the Standards, an LED lamp (often referred to as a "light bulb") with a screw-base is not an LED light engine with integral heat sink. In §130(d)1 it is clear that any luminaire with a line-voltage lamp holder (including a medium screw-based socket) shall be classified as low efficacy, regardless of the type of lamp that is initially installed in the luminaire. Therefore an LED lamp screwed into an incandescent luminaire shall not be classified as high efficacy.
8. Exception 2 to §150(k)2A establishes that GU-24 is the only line-voltage lamp holder that may be classified as high efficacy under certain conditions. See Section 6.2.1 for more information about when a luminaire with a GU-24 lamp holder may be classified as high efficacy. Also, see Section 6.2.1 for more information about when high efficacy LED trims may be classified as high efficacy.

## 6.3

### Switching Devices and Controls

The use of lighting controls is an important component of the Residential Lighting Standards. This section describes lighting control requirements for the Residential Lighting Standards.

### **6.3.1**

#### **Certification of Residential Lighting Controls**

Manual-on/automatic-off occupant sensors (also known as vacancy sensors), motion sensors (used for outdoor lighting), and dimmers installed to comply with §150(k) must be certified according to the applicable requirements of §119. Additional information about certifying devices to the Energy Commission is in Section 6.2.9.

### **6.3.2**

#### **Switching Requirements §150(k)7**

Following are controls that are required for compliance with the Residential Lighting Standards:

**Permanently Installed Luminaires.** All permanently installed high efficacy luminaires must be switched separately from low efficacy luminaires.

**Exhaust Fans.** There are two options for the switching of lighting associated with exhaust fans:

1. All lighting must be switched separately from exhaust fans, or
2. For an exhaust fan with an integral lighting system, the lighting system must be able to be manually turned on and off while allowing the fan to continue to operate for an extended period of time. An exhaust fan may need to run continuously if used to comply with §150(o).

**Readily Accessible Manual Controls.** All permanently installed luminaires shall be switched with readily accessible controls that permit the luminaires to be manually switched on and off.

**Manufacturer Instructions.** All lighting controls and equipment shall be installed in accordance with the manufacturer's instructions.

**Multiple Switches.** This requirement applies to all 3-way, 4-way, and other lighting circuits controlled by more than one switch. A lighting circuit controlled by more than one switch where a dimmer or vacancy sensor has been installed to comply with §150(k) shall meet the following conditions:

1. No controls shall bypass the dimmer or vacancy sensor function, and
2. The dimmer or vacancy sensor shall be certified to the Energy Commission that it complies with the applicable requirements of §119.

### **6.3.3**

#### **Energy Management Control System**

§119

Lighting control devices may be either individual devices or systems consisting of two or more components. Therefore, options allowing compliance through the use of lighting controls may be met through the use of an individual lighting control device or an energy management control system.

All lighting control devices installed for compliance with the Residential Lighting Standards must be certified to the Energy Commission. See Section 6.3.1 for additional information about certifying lighting control devices to the Energy Commission.

For control systems consisting of two or more components, such as an Energy Management Control System (EMCS), the manufacturer of the control system shall certify each of the components required for the system to comply with §119.

### **6.3.4**

## Vacancy Sensors

§150(k)10 and 11

The Residential Lighting Standards require the installation of high efficacy lighting, but allow vacancy sensors to be used as an alternate compliance option in any room or area that is not a kitchen. The Standards do not require a vacancy sensor to be used with any high efficacy luminaire. If there are rooms or areas where there are safety concerns regarding the use of vacancy sensors, then compliance through the use of high efficacy lighting may be preferable.

Manual-on / automatic-off occupant sensors, also known as vacancy sensors, automatically turn lights off if an occupant forgets to turn them off when a room is unoccupied. Additionally, these sensors shall provide the occupant with the ability to turn the lights off manually upon leaving the room, and turn them on manually upon entering the room. The manual-off feature is critical because it provides the occupants with the flexibility to control the lighting environment to their satisfaction, and results in greater energy savings by allowing the occupants to turn off the lights when they are not needed.

§119

Vacancy sensors are required to be certified to the Energy Commission as meeting all of the following requirements:

1. Provides the occupant with the ability to manually turn the lights on and off, and
2. Shall be capable of turning off the lighting automatically within 30 minutes or less after the room has been vacated in response to the absence of occupants in the room, and
3. Have a visible status signal that indicates that the device is operating properly or that it has failed or malfunctioned. The visible status signal may have an override switch that turns the signal off, and
4. Shall not turn on the lighting automatically, except the sensor shall have a grace period of 15 seconds to 30 seconds to turn on the lighting automatically after the sensor has timed out, and
5. Shall not have an override switch that disables the vacancy sensor, and
6. Shall not have an override switch that converts the sensor from a manual-on to an automatic-on system.

Vacancy sensors commonly on the market are wired in two different ways:

1. Where sensor operating current uses the load connection (two-wire connection).
2. Where sensor operating current uses a neutral connection (three-wire connection).

Some vacancy sensors using the load connection for operating current have minimum load requirements. For example, a vacancy sensor may require that bulbs rated over 25W be installed before the sensor will work. However, if an occupant later installs a screw-in compact fluorescent lamp that is rated less than 25W, the sensor may no longer work. Therefore, it is critical to select a sensor that has a low enough minimum load requirement to accommodate however small a load the occupant may install into the socket. The sensors that have a minimum load requirement are typically the ones that are designed to operate without a neutral wire in the switch box which is a common wiring scheme in older residential units.

A better solution would be to install a vacancy sensor that does not have minimum load requirements.

Vacancy sensors that are designed to take advantage of the neutral wire in the switch box typically do not have a minimum load requirement and are the preferred choice to meet the requirements of the Residential Lighting Standards.

Using vacancy sensors that uses the ground wire for the operating current is not recommended. There are potential safety concerns with using the ground to carry current

in residential applications.

If you are trying to control a lighting fixture from two different switches you may want to use a ceiling mounted rather than a wall switch occupant sensor, or use 3-way vacancy sensors at both switch locations.

#### Example 6-1

##### **Question**

We would like to use incandescent lighting in a bathroom along with a vacancy sensor. Although the sensor has the “manual-on” capability, it also has the capability of turning the lights on automatically by flipping a switch that is located under the switchplate cover. Does this sensor meet the requirements of the Residential Lighting Standards?

##### **Answer**

No, this sensor does not meet the requirements of the Standards. §119 requires that the vacancy sensor shall not have an override switch that converts the sensor from a manual-on to an automatic-on system.

#### Example 6-2

##### **Question**

Must the sensor in the example above give the occupant the option of turning the light off manually upon leaving the bathroom?

##### **Answer**

Yes. The sensors must provide the occupant with the option to turn the lights off manually upon leaving the space. If the occupant forgets to turn the lights off when a room is left unoccupied then the occupant sensor must turn the lights off automatically within 30 minutes. The lights must then be manually switched back on when the lights are needed again. This option provides the occupants with the flexibility to control the lighting environment to their satisfaction, and results in greater energy savings by allowing the occupants to turn off the lights when they are not needed.

#### Example 6-3

##### **Question**

What are our options if we want to use an automatic-on occupant sensor in a bathroom, garage, laundry room, or utility room?

##### **Answer**

You can use automatic-on sensors only in conjunction with high efficacy luminaires. With high efficacy luminaires you may use a toggle switch, vacancy sensor, or automatic-on sensor. With luminaires in these rooms that are not high efficacy you must use a vacancy sensor.

### **6.3.5**

#### **Residential Dimmers**

§150(k)11

One of the alternate options to using high efficacy lighting in any room that is not a kitchen, bathroom, garage, laundry room, closet greater than 70 ft<sup>2</sup>, or utility room is the use of dimmers.

Dimmers are required to be certified to the Energy Commission as meeting all of the following requirements:

1. Be capable of reducing power consumption by a minimum of 65 percent when the dimmer is at its lowest light level, and
2. If the device is a dimmer controlling incandescent or fluorescent lamps, provide electrical outputs to lamps for reduced visual flicker operation through the dimming range, and
3. Be listed by a rating lab recognized by the International Code Council (ICC) as being in compliance with Underwriters Laboratories Standards, and
4. If the device is a wall box dimmer designed to be used in a 3 or more-way circuit with non-dimmable switches, the level set by the dimmer shall not be overridden by any of the switches in the circuit. The dimmer and all of the switches in the circuit shall have the capability of turning lighting OFF if it is ON, and turning lighting ON to the level set by the dimmer if the lighting is OFF. Any wall box dimmer that is connected to a system with an emergency override function shall be controlled by the emergency override, and
5. If the device is a stepped dimmer, shall include an off position to turn lights completely off.

There are 3-way, 4-way, and other multiple location dimming circuit combinations (multi-way) where a single multi-way dimmer can be combined with other multi-way dimmers, or combined with multi-way toggle switches. The Residential Lighting Standards do not prohibit the combination of dimmers and regular toggle switches, provided that the toggle switches never override the dimmer control.

The Residential Lighting Standards require that, when using a dimmer as the alternate compliance option to high efficacy lighting, the dimmer must control the low efficacy lighting. This control requirement applies equally to 2-way, 3-way, 4-way switching; or any other multiple switching combinations. No controls shall bypass a dimmer where it has been installed to comply with §150(k). If a control bypasses a dimmer, that dimmer can no longer be said to control the lighting.

For example, when using 3-way dimmers combined with a 3-way toggle switch: If the dimmer is set at 50 percent power, the toggle switch at the other end of a room must not bypass or change the 50 percent power level.

In some small rooms, it may be practical to use a multi-way toggle switch in combination with a multi-way dimmer.

However, in large rooms, long hallways, and on stairways, lighting levels may occasionally be inadequate if a multi-way dimmer is used in only one switch location, and the other switch locations use non-dimmable toggle switches. For example, installing a dimmer on one floor, and a regular toggle switch on another floor, may occasionally result in inadequate light levels on a stairway. Therefore, dimming solutions where the lights can be dimmed from ALL locations are recommended in stairways and hallways. For example, it is preferred to install a multi-way dimmer on each floor of a stairway instead of a multi-way dimmer on one floor of the stairway and a regular toggle switch on another floor.

It is important to correctly match the dimmer with the type of lighting load that is being dimmed. Failure to correctly match the dimmer with the electrical lighting load may result in early equipment failure, including the dimmer, transformer, ballast, or lamp.

Dimmer manufacturers typically offer three basic types of incandescent dimmers: Line voltage (120 volt), low-voltage for use with a magnetic transformer, and low-voltage for use with an electronic transformer. Line voltage incandescent lamps, including tungsten-halogen lamps, can easily be dimmed over their full range of output with voltage control or phase control (electronic) dimmers. Tungsten-halogen lamps can be dimmed

with conventional incandescent dimmers, generally without any special considerations. When dimming a low voltage load, additional components are required in the dimmer to avoid overheating the transformer. UL has separate requirements for 120-volt and low-voltage dimmers due to the heat concern with transformers.

All fluorescent lamps 13W or greater, with electronic ballasts, and meeting the minimum lumens per watt already comply with Residential Lighting Standards. Even though high efficacy fluorescent lamps with electronic ballasts do not require dimmers to meet Standards, dimmers are permitted to be used with fluorescent lighting systems. Most fluorescent lamps cannot be properly dimmed with the same simple wallbox devices typically used for dimming incandescent lamps. A special control and dimming ballast must be used. Some types of screw-in compact fluorescent lamps with integral ballasts can be dimmed by simple controls. However, many screw-in compact fluorescent lamps cannot be dimmed at all.

## 6.4

### Kitchens

§150(k)9.

The Residential Lighting Standards define a residential kitchen as “a room or area used for food storage and preparation and washing dishes including associated counter tops and cabinets, refrigerator, stove, oven, and floor areas.”

Kitchen lighting includes all permanently installed lighting in the kitchen, except for lighting that is internal to cabinets for the purpose of illuminating only the inside of the cabinets. Lighting in areas adjacent to the kitchen, including but not limited to dining and nook areas, are considered kitchen lighting if they are not separately switched from kitchen lighting.

The intent of the kitchen lighting Standards is to insure that the builder provides the occupant with energy efficient lighting. The permanently installed lighting should provide sufficient light levels for basic kitchen tasks without the need for portable (plug-in) lighting.

### 6.4.1

#### **Determine High Efficacy and Low Efficacy Installed Wattage**

§150(k)8

The Residential Lighting Standards require that at least half the lighting watts installed in a kitchen must be consumed by high efficacy luminaires. For example, if 150W of high efficacy lighting is installed, no more than 150W of low efficacy lighting can be installed. See Sections 6.2.1 and 6.2.2 for descriptions of high and low efficacy luminaires.

Because high efficacy luminaires typically consume less power than other luminaires, about three-fourths of the luminaires in the kitchen are likely to be high efficacy. Form CF-6R-LTG-01, the Residential Lighting Installation Certificate, found in Appendix A, must be completed to determine if kitchen lighting complies with the Standards, and must be completed for all residential lighting installations.

There are no limits to the total number of watts that can be installed in a residential kitchen. Therefore, there are no limits to illumination levels. If higher illumination levels are needed, simply install additional wattage from high efficacy luminaires until needed illumination levels are reached.

#### Example 6-4

#### **Question**

I am designing a residential kitchen lighting system where I plan to install six 26W compact fluorescent recessed downlights, and four 24W linear fluorescent under cabinet luminaires. How many watts of incandescent lighting can I install?

**Answer**

First, determine the rated input watts of the fluorescent lighting system, including any additional wattage used by the ballasts. For this example, let's assume that the downlights with electronic ballasts are rated by the ballast manufacturer as consuming 26W, and the under cabinet luminaires with electronic ballasts are rated by the ballast manufacturer as 25W.

$$26 \times 6 = 156W$$

$$25 \times 4 = 100W$$

$$\text{Total} = 256W$$

Therefore, the maximum watts of incandescent lighting that can be installed is 256W.

Example 6-5

**Question**

In the above example, if I plan to use 40W incandescent lamps (bulbs) in luminaires that have a relamping rated wattage of 90W, how many incandescent luminaires can I install?

**Answer**

The installed incandescent wattage is based upon the relamping rated wattage of the luminaire, and not by the wattage of the lamp. Two 90W incandescent luminaires = 180W, and three-90W incandescent luminaires = 270W. Because no more than 256W of low efficacy lighting can be installed in the above kitchen, only two-90W incandescent luminaires may be installed. The additional 76W of low efficacy lighting may be installed somewhere else in the kitchen, provided that the total installed relamping rated wattage does not exceed the 76W still available. Alternatively, four-60W incandescent luminaires (240W) can be installed in the kitchen.

Example 6-6

**Question**

In the above example, if I plan to use low-voltage incandescent halogen lamps with transformers rated at 40W each (in this example, let's assume that 40W includes the input wattage of the transformer + the lamp), how many of these low-voltage incandescent luminaires can I install?

**Answer**

The installed of low-voltage lighting is based upon the rating of the transformer. You are allowed up to 256W of low efficacy lighting

$$256 \text{ divided by } 40 = 6.4 \text{ luminaires}$$

You are allowed to install 6 low-voltage incandescent halogen luminaires with transformers rated at 40W each.

Example 6-7

**Question**

In the previous example, if I plan to use 15W LED luminaires which has not been certified to the Energy Commission as high efficacy, how many of these LED luminaires can I install?

**Answer**

LED lighting, which has not been certified by the Energy Commission as high efficacy, shall be classified as low

efficacy lighting. The installed LED system wattage must include transformers, power supplies, and any other power consuming components. You are allowed up to 256W of low efficacy lighting.

In this example, let's assume a system input wattage of 15W per LED luminaire:

256 divided by 15 = 17 luminaires

You are allowed to install 17 low efficacy LED luminaires with system input wattage of 15W each.

### 6.4.2

#### **Kitchen Low Efficacy Tradeoff Option**

Exception to §150(k)8

There is a residential kitchen lighting “tradeoff” option available where additional low efficacy lighting is needed, provided that other conditions are met.

Once it has been determined that the installed low efficacy lighting wattage is no greater than the installed high efficacy wattage, a limited number of additional low efficacy lighting wattage may be installed. The additional low efficacy wattage shown below in Table 6-5 may be installed provided that all of the following conditions are met:

1. All installed low efficacy luminaires in the kitchen are controlled by a manual-on occupant sensor, dimmer, energy management control system (EMCS), or a multi-scene programmable control system, and
2. All permanently installed luminaires in garages, laundry rooms, closets greater than 70 ft<sup>2</sup>, and utility rooms are high efficacy and are also controlled by a vacancy sensor.

See Section 6.3.1 for requirements to certify lighting controls.

Table 6-5 Additional Low Efficacy Wattage Tradeoff

Size of Individual Dwelling Unit	Additional low efficacy lighting allowed in a residential kitchen
Less than or equal to 2,500 ft <sup>2</sup>	Up to an additional 50 W
Larger than 2,500 ft <sup>2</sup>	Up to an additional 100 W

Example 6-8

#### **Question**

I am designing kitchen lighting for a 2,400 ft<sup>2</sup> house. My design exceeds the 50 percent low efficacy lighting ratio in my kitchen. This design includes 208W of high efficacy lighting. I plan to control the low efficacy lighting in the kitchen with a multi-scene programmable control system, and install both high efficacy lighting and vacancy sensors in the garage, laundry room, all closets greater than 70 ft<sup>2</sup>, and the utility room. How many watts of low efficacy lighting can I install in my kitchen?

#### **Answer**

You are allowed an additional 50W of low efficacy lighting in the kitchen because the house is less than 2,500 ft<sup>2</sup>. You are also allowed 208W of low efficacy lighting based upon the watts of high efficacy lighting you are installing.

50W + 208W = 258W.

You are allowed to install up to 258W of low efficacy lighting in the kitchen.

### 6.4.3



## Lighting Internal to Cabinets

Lighting internal to cabinets is not considered when determining that at least 50 percent of the permanently installed lighting in a residential kitchen is high efficacy. Permanently installed lighting that is internal to cabinets shall use no more than 20W of power per linear foot of illuminated cabinet.

Lighting that is internal to cabinets is defined as lighting installed inside of a cabinet only for the purpose of illuminating the inside of the cabinet. Lighting installed for the purpose of illuminating surfaces outside of kitchen cabinet is not considered lighting internal to cabinets. The following lighting systems are not considered lighting internal to cabinets:

1. Lighting recessed into a cabinet for the purpose of illuminating surfaces outside of the cabinet.
2. Lighting attached to any surface on the outside of a cabinet, including the top, bottom, or sides.
3. Lighting attached to the inside of a cabinet, such as reflector lamps, for the purpose of projecting light out of the cabinet.

### Example 6-9

#### Question

I have 23 lf of upper kitchen cabinets, and 32 ft of lower kitchen cabinets. I want to install lighting on the inside of 18 ft of upper cabinets which have glass doors. The upper cabinets have three shelves. I want to install lights under all three shelves. How many watts of lighting may I install in the cabinets?

#### Answer

The cabinet lighting allowance is based upon the linear foot of illuminated cabinet, regardless of the number of shelves in each cabinet. Therefore, multiply 18 ft times 20W per foot = 360W. You are allowed to install up to 360W of internal cabinet lighting.

### Example 6-10

#### Question

In the above example, if I have 18 lf of upper cabinets with glass doors, but I only want to install lighting in 10 lf of the cabinets, how many watts of lighting may I install in the cabinets?

#### Answer

The allowance is based upon the linear feet of cabinet that is illuminated. In this case, multiply 10 ft time 20W/ft = 200W. You are allowed to install up to 200W of internal cabinet lighting.

### Example 6-11

#### Question

I want to install track lighting on my kitchen ceiling to illuminate the inside of my kitchen cabinets, from the outside of the cabinet and through the glass doors. Am I allowed 20W/lf of glass door for this lighting task?

#### Answer

No, the 20W/ft<sup>2</sup> for illuminated cabinet applies only to lighting that is installed inside of the cabinet, and which has been installed only for the purpose of illuminating the inside of the cabinets.

Example 6-12

### Question

In the above example, I am installing puck lights under the shelves of the cabinets with glass doors. Some of the lighting will inadvertently spill through the glass. Is this still considered lighting only for the purpose of illuminating the inside of the cabinets?

### Answer

Yes, this is still considered lighting for the purpose of illuminating the inside of the cabinets because the lighting system is specifically designed for illuminating the inside of the cabinets. However, if a lighting different lighting system, such as adjustable flood lights, is designed to project lighting on to surfaces external to the cabinets, that lighting will be considered permanently installed kitchen lighting, and not internal cabinet lighting.

## 6.4.4

### Kitchen Lighting Controls

High-efficacy fixtures and low efficacy fixtures are required to be switched separately. See Section 6.3 for additional information on residential lighting controls. It is also recommended to separately switch different layers of the kitchen lighting. Each layer that can serve a unique function should have the ability to operate independently.

The following are some examples of layers that code may allow to be switched together but are recommended to be switched separately:

1. Recessed downlights.
2. Linear fluorescent luminaires mounted on the ceiling.
3. Under-cabinet lighting.



Under-cabinet lighting using 14W and 28W T5 linear fluorescent lamps

Source: [www.gelighting.com](http://www.gelighting.com)

Figure 6-7 – Kitchen Work Surface Lighting

4. In uplights (mounted on walls or on top of cabinets). Uplights are effective at making rooms less gloomy, so if an uplight is provided people may choose not to switch on the other lights in the room.
5. Low efficacy luminaires must be switched on a separate circuit from the high efficacy luminaires. These could include low-voltage halogen MR lamps or reflector lamps used to provide decorative spotlighting.
6. Lighting in areas adjacent to the kitchen, such as dining and nook areas and even family rooms, is considered to be kitchen lighting if it is not separately switched from the kitchen lighting. The switches may be mounted on the same faceplate, but as long as the lights can be switched independently, these areas do not count as being in the kitchen.



Recessed cans with 18W CFLs light specific task areas



Wall-mounted uplighters using 32W CFLs increase the sense of space

Figure 6-8 – General Kitchen Lighting

See Section 6.2.3 of this Compliance Manual for information on determining the input power (wattage) of each installed luminaire.

#### Example 6-13

##### **Question**

I am using an incandescent luminaire over the sink that is capable of housing a 150W lamp. I plan to install a 26W compact fluorescent lamp in the socket. Does this qualify as a high efficacy luminaire and what wattage should I use in determining if half the lighting power in the kitchen is high efficacy?

##### **Answer**

No, the luminaire does not count as high efficacy because it is capable of being lamped with an incandescent lamp. Use the maximum rated power (150W) for determining the percent of high efficacy lighting.

#### Example 6-14

##### **Question**

If I use track lighting in a kitchen, how do I calculate the power?

##### **Answer**

See §130(d) or Section 6.2.4 of this Residential Compliance Manual. For line voltage track, use the maximum relamping wattage of all of the installed luminaires as listed on permanent factory-installed labels, or 45W/lf of track, whichever is larger. An alternate method is to calculate the power based on the volt-ampere rating of the branch circuit feeding the track, or the volt-ampere of a current limiter integral to the track. For low-voltage tracks, use the rated watts of the transformer as listed on a permanent factory-installed label.

#### Example 6-15

##### **Question**

I am doing minor renovations to my kitchen that has six recessed incandescent cans and I am adding a new luminaire over the sink. Does this luminaire have to be a high efficacy luminaire?

##### **Answer**

Yes, all new luminaires must be high efficacy until at least 50 percent of the total lighting wattage comes from high efficacy luminaires (§152(b)1 and §152(b)2).

#### Example 6-16

##### **Question**

I am completely remodeling my kitchen and putting in an entirely new lighting system. How do the Residential Lighting Standards apply to this case?

##### **Answer**

At least half the lighting watts must be high efficacy luminaires. This is treated like new construction.

## Example 6-17

### Question

Where does the kitchen lighting stop and the other lighting begin in the case of a large family room with the kitchen on just one side of an approximately 24-ft by 24-ft room. Is the kitchen nook part of the kitchen? Lighting over the eating counter? Lighting in an adjacent pantry?

### Answer

Lighting over food preparation areas is kitchen lighting, including areas used for cooking, food storage and preparation and washing dishes, including associated countertops and cabinets, refrigerator, stove, oven, and floor areas. Any other lighting on the same switch is also kitchen lighting, whether or not the luminaires are in the kitchen area. Lighting for areas not specifically included in the definition of a kitchen, like the nook or the family room, is not kitchen lighting, as long as it is switched separately.

## Example 6-18

### Question

I am installing an extraction hood over my stove, it has lamps within it. Do these lamps have to be high efficacy?

### Answer

This lighting is part of an appliance, and therefore does not have to meet the Residential Lighting Standards for permanently installed lighting. This lighting is ignored in determining if half the kitchen lighting is high efficacy.

## 6.5

### Bathrooms, Garages, Laundry Rooms, Closets, and Utility Rooms

§150(k)10

Lighting in bathrooms, garages (attached and detached), laundry rooms, closets and utility rooms must be high efficacy, or must be controlled by a vacancy sensor. See Section 6.3 for information on residential lighting controls.

Garages, laundry rooms, closets and utility rooms can be lit entirely by high efficacy lighting. Linear fluorescent luminaires are typically between 1.5 and 4 times as efficient as CFLs, and should be used unless there is insufficient space. Luminaires should be mounted close to washer/dryer hookups and over work surfaces to ensure shadow-free illumination.

#### 6.5.1

### Bathrooms

§101 definitions

A **bathroom** is a room or area containing a sink used for personal hygiene, toilet, shower, or a tub.

If a sink used for personal hygiene is in a room other than a bathroom, such as bedroom, where no doors, walls, or other partitions separate the sink area from the rest of the room, and the lighting for the sink area is switched separately from room area lighting, only the luminaire(s) that are lighting the sink area must meet the bathroom lighting requirements; in this case, lighting of the sink area includes lighting of associated counters, cabinets, and mirrors.

More than one circuit of luminaires may be attached to the same vacancy sensor.

Where automatic shutting off of lights by a vacancy creates a safety concern, the Residential Lighting Standards allow compliance through the use of high efficacy

luminaires, which when installed, does not require the use of a vacancy sensor. For safety in bathrooms, it is recommended that at least one high-efficacy luminaire should be installed so that it is not controlled by the vacancy sensor circuit. This will help to ensure that all of the luminaires don't switch off while someone is in the bath. Even dual technology sensors may not detect a motionless and silent occupant.

### **6.5.2**

## **Garage**

§101 definitions

A **garage**, for compliance with the Residential Lighting Standards, is a non-habitable building or portion of building, attached to or detached from a residential dwelling unit, in which motor vehicles are parked.

Garages present an opportunity to reduce energy use by providing task lighting. The end of the garage furthest from the door to the house is often used as a work area, and can be provided with high efficacy luminaires switched separately from the rest of the space.

See Section 6.2.6 for information about when lighting integral to garage door openers does and does not have to be included as permanently installed lighting in a garage.

### **6.5.3**

## **Laundry Room**

§101 definitions

A **laundry room** is a non-habitable room or space which contains plumbing and electrical connections for a washing machine or clothes dryer.

### **6.5.4**

## **Closets**

§101 definitions

A **closet** is a non-habitable room used for the storage of linens, household supplies, clothing, non-perishable food, or similar uses, and which is not a hallway or passageway.

Exception 2 to §150(k)10

Closets less than 70 ft<sup>2</sup> are exempt from these requirements. However, a hallway having storage shelves, such as a butler's cupboard, shall not be exempt because it is considered a hallway for compliance with the Residential Lighting Standards.

### **6.5.5**

## **Utility Room**

§101 definitions

A **utility room** is a non-habitable room or building which contains only HVAC, plumbing, or electrical controls or equipment; and which is not a bathroom, closet, garage, or laundry room.

### **6.5.6**

## **Combined High Efficacy and Vacancy Sensor Option**

See Section 6.4.2 for information about the option to install both high efficacy lighting and vacancy sensors in garage, laundry, closets greater than 70 ft<sup>2</sup>, and utility rooms, to obtain additional kitchen low efficacy lighting.

Although not required, vacancy sensors can be used in conjunction with high efficacy lighting to achieve the lowest possible energy use. If there are any concerns about safely using vacancy sensors in conjunction with low-efficacy luminaires in a space, consider the following two options:

1. In addition to the low efficacy luminaires controlled by a vacancy sensor, leave one high efficacy luminaire on a separate manual switch.

2. Install all high efficacy luminaires in the space; high efficacy luminaires do not require a vacancy sensor to meet the requirements of the Residential Lighting Standards.

Example 6-19

**Question**

What types of vacancy sensors qualify for controlling low efficacy lights in bathrooms, garages, laundry, closets, and utility rooms?

**Answer**

Eligible vacancy sensors are those which have been certified to the Energy Commission. These vacancy sensors (manual-on / automatic-off occupancy sensors) do not allow the luminaire to be turned on automatically and do not have an override that allows it to remain on.

Sensors including microwave, ultrasonic and passive infra-red (PIR) must be certified to the Energy Commission as complying with the applicable provision of §119.

See Section 6.3.3 for more information about vacancy sensors.

Example 6-20

**Question**

Is it good lighting practice to have all the lighting in a room controlled by a single vacancy sensor?

**Answer**

Vacancy sensors may fail to detect people who aren't making large movements, and their sensitivity is reduced in hot environments. Vacancy sensors may cause the lights to switch off while someone is using a hazardous device. Where safety is an issue, high efficacy luminaires should be installed. High efficacy luminaires do not require a vacancy sensor to meet the Residential Lighting Standards.

Example 6-21

**Question**

Is the factory installed lighting system in a bathroom mounted medicine cabinet required to be either high-efficacy or controlled by a vacancy sensor?

**Answer**

If the factory installed lighting in a medicine cabinet is designed to only illuminate the inside of the medicine cabinet, and the lighting is controlled only by a door activated switch where the lights turn off automatically when the cabinet door is closed, then the factory installed lighting is not regulated by the Residential Lighting Standards. However, if the factory installed lighting is connected to a manually operated switch that can be turned on regardless of the position of the cabinet door, or the lighting is designed to illuminate or display the contents of the cabinet when the door is closed, then it is considered permanently installed lighting that must comply with the Residential Lighting Standards. Also, any factory installed "bath bar" or other general lighting system integrated into the medicine cabinet is considered permanently installed lighting that must comply with the Residential Lighting Standards.

Example 6-22

**Question**

Is the factory installed lighting in a built-in ironing board device required to be either high-efficacy or controlled by a **vacancy sensor when it is installed in a laundry room?**

**Answer**

Yes, if the lighting is permanently attached it must be either high-efficacy or controlled by a vacancy sensor. See Section 6.2.6 for additional information about permanently installed luminaires.

**6.6  
Other Rooms**

§150(k)11

Permanently installed lighting in other rooms has three compliance options. The lighting must be high efficacy, controlled by a vacancy sensor, or controlled by a dimmer. See Section 6.3 for lighting control requirements.

“Other rooms” include any room or area that is not a kitchen, bathroom laundry, garage, closet, or utility room. Other rooms include hallways, dining rooms, family rooms, club house, home office, and bedrooms – the rooms in which people are most aware of interior design both in terms of fashion and the usability of their living space. See Section 6.4 for a definition of a kitchen, and Section 6.5 for definitions of bathroom, laundry, garage, closet, and utility room.

Exception 2 to §150(k)11

Lighting in detached storage buildings less than 1000 ft<sup>2</sup>, when those storage buildings are located on a residential site, are not required to comply with §150(k)11.

There are rooms in many houses for which permanently installed lighting has not been provided. Instead, these rooms are often provided with switched receptacles, sometimes called, “half-hots.” Many people commonly add their own portable lighting. Unfortunately, portable lighting often means highly inefficient incandescent floor-standing luminaires that can consume 190W or more for older lamps.

Permanently installed lighting should reduce the need for such high wattage portable sources by creating variations of light throughout the room, and by reducing areas of shadow. To achieve this, use several luminaires rather than a single luminaire; wall-mounted uplights are a good choice because they are design-neutral and can be repainted. For high-end properties, linear fluorescent or LED cove lighting and other forms of concealed lighting may increase marketability.

People like to control the appearance of their rooms; providing separate switches for each luminaire will make the space more attractive to tenants and will allow them to reduce their energy use.

Although vacancy sensors can be used in living spaces, there are limitations in those living spaces where people are expected to sit still for long periods of time and not move around enough to keep the sensor activated, resulting in lights going off prematurely.

Example 6-23

**Question**

Can a ceiling fan with integrated lighting be a high efficacy luminaire?

**Answer**

Yes. Ceiling fan light kits with integral CFL ballasts are available. Some LED lighting may qualify as high efficacy. LED lighting must be certified to the Energy Commission before it can be classified as high efficacy. See Section 6.2.10 for more information about requirements for residential LED lighting.



Some occupants are likely to prefer obscured lamps to visible lamps. A less efficient alternative, when the ceiling fan is installed in a room other than a kitchen, bathroom, garage, laundry room and/or utility room, is to use incandescent lamps on a dimming circuit separate to the fan circuit.

#### Example 6-24

#### Question

Are high-efficacy spotlights available, to replace halogen MR16s?

#### Answer

Some CFLs resemble spotlights, and manufacturers may describe them as spotlights, but they produce the same diffuse light as regular CFLs. Metal halide spotlights with 35W T-6 high efficacy lamps are available, and LEDs can be used as spotlights. LED lighting must be certified to the Energy Commission before it can be classified as high efficacy. See Section 6.2.10 for more information about requirements for residential LED lighting.

### 6.7

#### Outdoor Lighting

§150(k)13

Luminaires providing outdoor lighting, including outdoor lighting for private patios on low-rise residential buildings with four or more dwelling units, entrances, balconies, and porches, and which are permanently mounted to a residential building or to other buildings on the same lot shall be high efficacy luminaires, or they may be low efficacy luminaires if they are controlled by all three of the following lighting controls:

1. Controlled by a manual on/off switch, and
2. A motion sensor that is not equipped with an override or bypass switch that disables the motion sensor, and which automatically turns off the lights when no motion is detected, and
3. One of the following three methods to automatically turn the lights off during the daytime:
  - a. Photocontrol not having an override or bypass switch that disables the photocontrol;
  - b. Astronomical time clock not having an override or bypass switch that disables the astronomical time clock; or
  - c. Energy management control system (EMCS) not having an override or bypass switch that allows the luminaire to be always on.

The above lighting controls must be certified according to the applicable provisions of §119 before they can be installed. See Section 6.3.1 for more information on certifying lighting controls.

#### 6.7.1

##### Temporary Override of Motion Sensor on Outdoor Luminaires

Exception 2 to §150(k)13

§119 requires that motion sensors shall be capable of automatically turning off all the lights in an area no more than 30 minutes after the area has been vacated. However, there may be occasions where it is desirable to allow residential outdoor lighting to be on for more than 30 minutes after the sensor has stopped sensing activity. For example, when someone is entertaining in their backyard, they may want the lights to stay on longer than 30 minutes. To address this issue, the Residential Lighting Standards allow low efficacy outdoor luminaires to be controlled by a motion sensor controlled by a temporary override switch to bypass the motion sensing function, provided that the motion sensor is automatically reactivated within 6 hours. The motion sensor must

automatically reactivate itself without any action on part of the operator.

Permanently installed luminaires in or around swimming pools, water features, or other locations subject to Article 680 of the California Electric Code need not be high efficacy luminaires. It should not be assumed that all permanently installed lighting in the proximity of water features is subject to Article 680. See Section 6.7.5 for more information about lighting subject to Article 680 of the California Electric Code.

### **6.7.2**

#### **Address Signs**

§150(k)14

Internally illuminated address signs shall:

1. Comply with §148, or
2. Not contain a screw-base socket, and consume no more than 5 watts of power as determined according to §130(d).

### **6.7.3**

#### **Control Requirements**

§119

Control devices, including motion sensors and photocontrols, must have an indicator that visibly or audibly informs the operator that the controls are operating properly, or that they have failed or malfunctioned. A light emitting diode (LED) status signal is typically used to meet this requirement. The LED status signal is also practical for use as a commissioning tool. Another option is to use the lamp in the luminaire as the status signal, as long as the lamp fails in the off position. The intention of this requirement is that if the photocell or motions sensor fails the luminaire will not turn on until the control is fixed.

See Section 6.3 for more information about requirements for residential lighting controls.

### **6.7.4**

#### **Hot and Cold Environments**

Amalgam CFLs perform better at both very high and very low temperatures than non-amalgam versions, so are appropriate for outdoor lighting, although they can take a few minutes to reach full output. If instant start is important and temperatures may be low, specify a cold-weather-rated ballast. Alternatively, an incandescent source (fitted with a combination photocontrol/motion sensor) may be a good choice.

### **6.7.5**

#### **Exempt Outdoor Lighting**

§150(k)13

Lighting that is not permanently attached to buildings, such as decorative landscape lighting when it is not permanently attached to buildings, is not regulated by the Residential Lighting Standards. However, when landscape lighting is attached to a building, it is regulated by the Residential Lighting Standards.

Even though it is not required by the Standards, using a time clock or photocontrol on outdoor lighting not attached to buildings will help to prevent people from accidentally leaving these lights on during the day and will reduce energy use.

Exception 3 to §150(k)13

Permanently installed luminaires in or around swimming pools, water features, or other locations subject to Article 680 of the California Electric Code need not be high efficacy luminaires.

Refer to Article 680 of the California Electric Code to determine if lighting in the proximity of water features is subject to this article. Article 680 covers the following areas related to residential outdoor lighting:

1. Lighting installed directly above the water in an outdoor pool, spa, hot tub, or fountain.
2. Pool lighting in an area extending between 5 ft and 10 ft horizontally from the inside walls of a pool.
3. Spa, hot tub, or fountain lighting within 5 ft from the inside walls of the spa, hot tub, or fountain.
4. Underwater luminaires.

Example 6-25

**Question**

Do all residential outdoor luminaires have to be “cutoff” rated, or “flat glass” types?

**Answer**

Typical residential outdoor lighting does not have to be “cutoff” rated. However, residential parking lots for eight or more vehicles are required to meet the Nonresidential Standards, which do include cutoff requirements for luminaires greater than 175W. Even though not required for most residential outdoor lighting, cutoff luminaires are usually more efficient at providing light in the required area, so a lower wattage lamp and ballast can be used. Cutoff luminaires also reduce stray light and glare problems which can be a source of legal dispute between tenants or with neighboring property owners.

Example 6-26

**Question**

My house has a row of small incandescent bollards along the walk way to the front door. Do these have to be high efficacy?

**Answer**

No. The high efficacy requirement only applies to lighting mounted to the building.

Example 6-27

**Question**

I would like to install low-voltage landscape lighting in my yard. Are these required to be on a motion sensor and photocontrol?

**Answer**

No. Even though low-voltage lighting does not qualify as high efficacy lighting, lighting not attached to a building is exempt from this requirement.

Example 6-28

**Question**

If I install high efficacy lighting on the exterior of the building, can I then install lighting that is not high efficacy in the bathrooms?

**Answer**

No, there is no provision in the Residential Lighting Standards for a “tradeoff” between exterior lighting and any interior rooms. However, you do have the option of using a motion sensor and automatic daylight control in

conjunction with outdoor luminaires that are not high efficacy.

#### Example 6-29

#### Question

Does outdoor lighting on the patio of a high-rise residential building have to comply with the Residential or Nonresidential Lighting Standards?

#### Answer

If the patio outdoor lighting is separately controlled from inside of the dwelling unit, it must comply with the Residential Outdoor Lighting Standards. If the patio outdoor lighting is controlled outside of the dwelling unit, it must comply with the Nonresidential Outdoor Lighting Standards. For example, if the outdoor patio lighting is on a house meter not controlled from inside the dwelling unit, it must comply with the Nonresidential Outdoor Lighting Standards.

§130(c), Outdoor Lighting for High-rise Residential Dwelling Units and Hotel/Motel Guest Rooms, states: "Outdoor lighting that is permanently attached to the building, and is separately controlled from the inside of a high-rise residential dwelling unit or guest room shall comply with §150(k)13."

### 6.8

#### Parking Lots and Parking Garages

§150(k)13

§130, §131, §132, §134

§146, §147

§150(k)15

Parking lots and carports for a total of seven or fewer cars per site must meet the residential outdoor lighting requirements as applicable. See Section 6.7 for information about residential outdoor lighting requirements.

Parking garages, either attached to or detached from the dwelling unit, and which house seven or fewer cars shall meet the residential indoor lighting requirements. See Section 6.65 for information about residential lighting requirements for garages which house seven or fewer cars.

Parking lots and carports for a total of eight or more cars per site must meet the Nonresidential Outdoor Lighting Standards: §130, §132, §134, and §147.

Parking garages that house eight or more cars shall meet the interior lighting control and power requirements of the Nonresidential Standards. See the following sections for a complete view of the Nonresidential Garage Lighting Standards: §130, §131, §134, and §146.

Parking lots and garages for eight or more cars are generally associated with multifamily housing.

The Nonresidential Outdoor Lighting Standards include the following requirements for parking lots and car ports that accommodate a total of eight or more vehicles per site:

1. Luminaires rated for lamps over 100W must have a lamp efficacy of at least 60 lumens per watt, or be controlled by a motion sensor. This requirement primarily affects incandescent luminaires rated for 100W or higher, and mercury vapor luminaires rated for 100W or higher. Incandescent luminaires and mercury vapor luminaires which are rated for less than 100W are not affected by this requirement. Luminaires rated for use only with LED, compact fluorescent, linear fluorescent, metal halide, and high pressure sodium lamps are not affected by this requirement.
2. Luminaires with lamps rated over 175W shall be designated "cutoff" in a photometric

test report.

3. Luminaires shall be controlled by a photocontrol, or an astronomical time switch that turns the lighting off when daylight is available.

See the following sections for a complete view of the Nonresidential Outdoor Lighting Standards: §130, §132, §134, and §147.

Residential parking lots should be lighted uniformly to provide a sense of safety; this means that lighting should fill in shadows and dark corners. Two or more less powerful luminaires in different places are preferable to a single luminaire.

Example 6-30

**Question**

I have a low-rise multi-family complex with a total of 20 parking spaces. However, the parking spaces are arranged throughout the site in groups of only 4 spaces each. Are these parking spaces required to comply with the nonresidential outdoor lighting requirements?

**Answer**

Yes, these spaces are required to comply with the Nonresidential Outdoor Lighting Standards. Parking lots and carports for a total of eight or more cars per site must meet the nonresidential outdoor lighting requirements.

**6.9**

**Common Areas of Multi-family Buildings**

§150(k)16

Lighting for common areas of low-rise residential buildings with four or more dwelling units shall be high efficacy, or shall be controlled by an occupant sensor. Occupant sensors used in common areas may have the capability of turning the lights on automatically.

Common areas include areas like interior hallways, pool house, club house, and laundry.

The quality of light provided in common areas of apartments, condominiums, and townhouses must be particularly high, because older or visually impaired residents must be able to find their way safely through spaces that may contain unexpected obstacles. Providing a sufficient level of light is essential.

The lighting of staircases and stairwells is a particular safety concern; the best way to light stairs is with directional light from above, to maximize the contrast between treads and risers. CFL luminaires with reflectors provide this type of light with great efficiency.

Buildings of three stories or less are classified as low-rise. For buildings higher than three stories the Nonresidential Standards apply to all of the common areas. The local fire code may limit the options for the use of occupant sensors in corridors and stairways.

Example 6-31

**Question**

Does the lighting for an interior common-area hallway of a low-rise residential building with four or less dwelling units have to comply with the Residential or Nonresidential Lighting Standards?

**Answer**

No, the lighting of an interior common-area hallway of a low-rise residential building with four or less dwelling units

must comply with the Residential Lighting Standards.

Example 6-32

**Question**

Does the lighting for an interior common-area hallway of a high rise residential building have to comply with the Residential or Nonresidential Lighting Standards?

**Answer**

The lighting of an interior common-area hallway of a high rise residential building must comply with the Nonresidential Lighting Standards. Lighting inside the dwelling units must comply with the Residential Lighting Standards, and lighting for common areas must comply with the Nonresidential Lighting Standards

§130(b), Indoor Lighting in High-rise Residential Dwelling Units and Hotel/Motel Guest Rooms, states "The design and installation of all lighting systems, lighting controls and equipment in high-rise residential living quarters and in hotel/motel guest rooms shall comply with the applicable provisions of §150(k)."

**6.10**

**Luminaires Recessed in Ceilings**

§150(k)12

**6.10.1**

**Luminaires in Insulated Ceilings**

§150(k)12

Luminaires recessed in insulated ceilings can create a thermal bridge through the insulation. Not only does this degrade insulation performance, but it can also permit condensation on the cold surface of the luminaire if exposed to moist air; for instance, in a bathroom.

Luminaires recessed in insulated ceilings must meet three requirements:

1. They must be listed, as defined in §101, for zero clearance insulation contact (IC) by Underwriters Laboratories or other nationally recognized testing/rating laboratories. This enables insulation to be packed in direct contact with the luminaire.
2. They must have a label certifying that the luminaire has airtight construction. Airtight construction means that leakage through the luminaire will not exceed 2.0 CFM when exposed to a 75 Pascals pressure difference, when tested in accordance with ASTM E283.
3. They must be sealed with a gasket or caulking between the luminaire housing and ceiling, and must have all air leak paths between conditioned and unconditioned spaces sealed with a gasket or caulk, to prevent the flow of heated or cooled air out of the living areas and into the ceiling cavity.

The Residential Lighting Standards allow the use of either a gasket or caulking, and do not favor one of these methods over the other. See Section 6.11 for helpful information on what to look for to make sure that all air leak paths have been sealed.

Example 6-33

**Question**

Are luminaires installed on the inside of the conditioned space in a linear fluorescent "light box" that is recessed into the ceiling considered installed in an insulated ceiling?

**Answer**

If the inside of the light box is entirely enclosed within the building envelope by a permanent building surface such as gypsum board, and the box is completely sealed with so that there are no air leaks between the conditioned and unconditioned spaces, the building inspector may determine that this space is inside the conditioned area. Luminaires mounted inside the "light box" may be considered to be surface mounted on the inside of the conditioned space. Therefore, the building inspector may determine that these luminaires are not installed in an insulated ceiling.

Example 6-34

### **Question**

If a box made out of fiber board, cardboard, or other such surface is placed over the top of a recessed luminaire, so as to keep insulation from making direct contact with the luminaire, will this still be considered a luminaire in an insulated ceiling?

### **Answer**

This will be considered a luminaire in an insulated ceiling, and the luminaire is still required to meet all of the IC and AT requirements. Section 410.116(B) of the National Electric Code says that thermal insulation shall not be installed above a recessed luminaire, wiring compartment, or ballast unless it is identified for contact with insulation, Type IC. Therefore, a box made out of fiber board, cardboard, or other such surface is placed over the top of a recessed luminaire is not in accordance with the NEC and is not permitted.

Example 6-35

### **Question**

If a recessed luminaire is installed in the first floor ceiling of a two-story residence, and there is no insulation in the first floor ceiling, is the luminaire required to meet the IC/AT requirements?

### **Answer**

No, if there is no insulation in the ceiling, the luminaire it is not required to meet the IC/AT requirements. However, the building inspector may determine that there are significant air leak paths between the first floor ceiling and an exterior wall, and require that the air leak paths be sealed.

Example 6-36

### **Question**

If a factory manufactured fire rated luminaire housing is placed over a recessed luminaire in a multi-family residential dwelling unit, is the luminaire still required to comply with the IC requirements?

### **Answer**

There are limited applications where a non-IC luminaire may be used conjunction with a manufactured fire rated luminaire housing in a multi-family residential dwelling unit. However, the luminaire must still comply with all of the airtight requirements.

A non-IC luminaire may be used in an insulated ceiling in conjunction with a fire rated housing only if all three of the following conditions are met:

1. The multi-family dwelling unit is an occupancy type R1 or R2; and
2. The luminaire is recessed between different dwelling units that are regulated by California Building Code Section 712.4.1.2; and
3. The manufactured fire rated housing is rated for a minimum of 1 hour fire in accordance with UL 263.

## 6.10.2

### Ballasts for Recessed Luminaires

§119(n)

For recessed luminaires with compact fluorescent ballasts, the ballasts must be certified to the Energy Commission. For additional information on certifying ballasts and other devices to the Energy Commission, see Section 6.3.

The luminaire must be designed and installed to allow ballast maintenance and replacement to be readily accessible to building occupants from below the ceiling without requiring the cutting of holes in the ceiling.

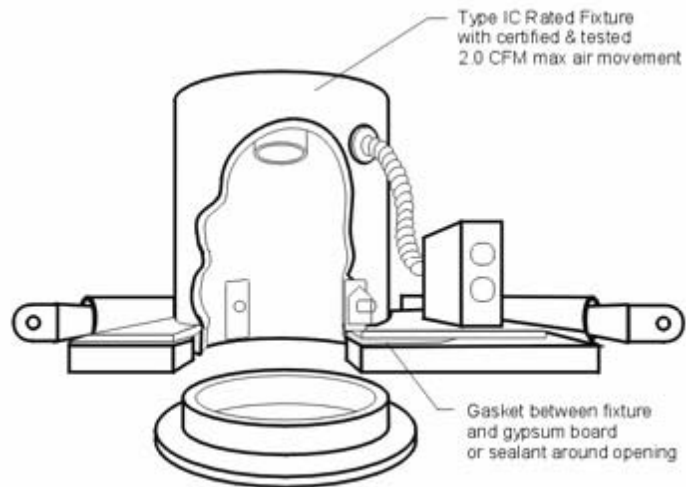

Figure 6-9 – Airtight, Type IC Luminaire

## 6.10.3

### Exhaust Fans

Note to §150(k)12B

An exhaust fan is not required to be certified airtight.

Note to §150(k)12C

An exhaust fan is required to be sealed with a gasket or caulk between the exhaust fan housing and the ceiling. However, the exhaust fan housing is not required to be certified airtight.

§150(k)6

Lighting attached or integral to exhaust fans is required to meet all of the applicable lighting requirements of §150(k). However, lighting which is part of a kitchen stove exhaust hood is not required to comply with §150(k).

See Sections 6.2.7 and 6.2.8 for more information about lighting attached to or integral to exhaust fans.

## 6.11

### Inspection Protocol for Recessed Luminaires in Insulated Ceilings

§150(k)12

Luminaires recessed in insulated ceilings must be IC rated and have a gasket or caulking between the housing and ceiling to prevent the flow of heated or cooled air between



conditioned and unconditioned spaces. The luminaire must include a label certifying airtight or similar designation to show air leakage less than 2.0 CFM at 75 Pascals when tested in accordance with ASTM E283. The label must be clearly visible for the building inspector. The building inspector may verify the IC and ASTM E283 labels at a rough inspection. If verified at final inspection the building inspector may have to remove the trim kit to see the labels.

The ASTM E283 certification is a laboratory procedure intended to measure only leakage of the luminaire housing or, if applicable, of an airtight trim kit, and not the installation. Luminaire housings labeled as airtight, airtight ready or other airtight designation do not establish that the luminaire has been installed airtight. The luminaire manufacturer must provide instructions that explain the entire assembly required to achieve an airtight installation.

The Residential Lighting Standards do not favor the use of gaskets over caulk, or the use of caulk over gaskets for compliance with the Standards. Because a luminaire housing is not always installed perfectly parallel to the ceiling surface, both methods have their benefits as follows:

1. Caulk will generally fill in and seal wide and uneven gaps. However, after the caulk dries, it may permanently attach the luminaire housing or trim to the ceiling surface. Therefore, the caulk may need to be cut away from the ceiling surface in the event that a luminaire housing or trim needs to be moved away from the ceiling.
2. Many gaskets allow the luminaire housing or trim to be readily moved away from the ceiling surface after it has been installed. However, if the gasket is too thin, or not made out of an air stopping type of material, it may not sufficiently reduce the air flow between the conditioned and unconditioned spaces.

There are several different methods used by manufacturers to meet the airtight standards. The Residential Lighting Standards do not favor one airtight method over another.

The primary intent is to install a certified airtight luminaire so that it is sufficiently airtight to prevent the flow of heated or cooled air between conditioned and unconditioned spaces. All air leak paths through the luminaire assembly or through the ceiling opening must be sealed. Leak paths in the installation assembly that are not part of the ASTM E283 testing must be sealed with either a gasket or caulk. One example may apply for assemblies where a certified airtight luminaire housing is installed in an adjustable mounting frame; all air leak paths between the certified airtight luminaire housing and the adjustable mounting frame must be sealed, either with a gasket or caulk.

Following is the process for verifying that the requirements for an airtight installation are met.

1. Manufacturer specifications (a "cut sheet") of the certified airtight luminaire housing(s) and installation instructions must be made available with the plans to show all components of the assembly that will be necessary to insure an airtight installation consistent with §150(k)5. This allows the building inspector to know what method the luminaire manufacturer specifies to achieve airtight installation, and therefore, at what phase of construction the building inspector must inspect the luminaire for airtight compliance.
2. One of the following primary methods is specified by the luminaire manufacturer to insure an airtight seal of the certified airtight housing to the ceiling:
  - a. A gasket is attached to the bottom of the certified airtight housing prior to the installation of the ceiling (i.e. drywall or other ceiling materials) to create an airtight seal. The gasket may be preinstalled at the factory, or may need to be field installed. For field installed gaskets, instructions on how the gasket is to be attached must be provided by the manufacturer. The luminaire must be installed so that the gasket will be sufficiently compressed by the ceiling when the ceiling is

installed.

- b. A gasket is applied between the certified airtight housing and the ceiling opening after the ceiling has been installed. The gasket creates the airtight seal. The cut sheet and installation instructions for achieving the airtight conditions must show how the gasket is to be attached.
- c. Caulk is applied between the certified airtight housing and the ceiling after the ceiling has been installed. The caulk creates the airtight seal. The cut sheet or installation instructions for achieving the airtight conditions must specify the type of caulk that must be used and how the caulk must be applied.
- d. A certified airtight trim kit is attached to the housing after the ceiling has been installed. The certified airtight trim kit in combination with the luminaire housing makes the manufactured luminaire airtight. Note that a decorative luminaire trim that is not ASTM E283 certified does not make the manufactured luminaire airtight. Most decorative luminaire trims are not designed to make a luminaire airtight. Rather, these trims are used to provide a finished look between the ceiling and luminaire housing, and may include a reflector, baffle, and/or lens. However, some trim kits are specifically designed to be a critical component used to make a luminaire installation airtight. These trim kits must be certified airtight in accordance with ASTM E283. Certified airtight trim kits typically consist of a one-piece lamp-holder, reflector cone, and baffle.
- e. The cut sheet and installation instructions for achieving the airtight conditions must show which certified airtight trim kits are designed to be installed with the luminaire housing, and how the certified airtight trim kits must be attached. A gasket must be installed between the certified airtight trim kit and the ceiling.

3. The following methods for insuring an airtight seal between the certified airtight housing or certified airtight trim and the ceiling must be field verified at different phases during construction:

- a. Gasket attached to the bottom of the certified airtight housing must be inspected prior to the installation of the ceiling when the rough-in electrical work is visible. The inspector must review the cut sheet or installation instructions to make sure the housing and gasket have been installed correctly. All gaskets shall be permanently in place at the time of inspection. It is important that once the ceiling material is installed the gasket will be in continuous, compressed contact with the backside of the ceiling and that the housing is attached securely to avoid vertical movement. The housing must be installed on a plane that is parallel to the ceiling plane to assure continuous compression of the gasket.
- b. Gasket applied between the certified airtight housing and the ceiling after the ceiling has been installed must be inspected after the installation of the ceiling. The inspector must review the cut sheet or installation instructions to make sure the housing and gasket have been installed correctly. The gasket shall be permanently in place at the time of inspection. It is important that the gasket is in continuous, compressed contact with the ceiling, and that the housing is attached securely to avoid vertical movement.
- c. Caulk applied between the certified airtight housing and the ceiling after the ceiling has been installed must be inspected after the installation of the ceiling. The inspector must review the cut sheet or installation instructions to make sure the housing has been installed correctly and the caulk has been applied correctly. It is important and that the housing is attached securely to avoid vertical movement.
- d. Certified airtight trim kit must be inspected after the installation of the ceiling and the installation of the trim. The inspector must review the cut sheet or installation instructions to make sure the luminaire housing and the certified airtight trim kit have been installed correctly. It is important that the housing and the certified airtight trim kit are attached securely to avoid vertical movement. The ASTM E283 certification is a laboratory procedure where the trim kit is tested on a smooth

mounting surface. However, it is common for certified airtight trim kits to be installed against a textured ceiling or other irregular ceiling surface. It is important that the gasket is in continuous, compressed contact with the ceiling and the certified airtight trim kit. Therefore, it is important to visually inspect the certified airtight trim kit and gasket next to the ceiling to assure that a continuous seal has been produced.

Certified airtight trim kits may be installed on luminaire housings that may or may not be certified airtight. If the trim kit is certified airtight, it must also have a sealed gasket between the trim kit and ceiling.

## 6.12

### Recommendations for Luminaire Specifications

It is important that luminaires are described fully in the specifications and on drawings so that contractors and subcontractors provide and install residential lighting systems that comply with the Residential Lighting Standards. The specifications should be clear and complete so that contractors understand what is required to comply with the Standards.

Following are a few suggestions to help reduce the chance that there may be costly change orders required to bring a non-complying building into compliance.

1. Include all applicable residential lighting requirements in the general notes on the drawings and other bid documents.
2. Include the residential lighting requirements with each luminaire listed in the lighting schedule text and details, for example:

Table 6-6 – Recommendations for Luminaire Specifications

Luminaire Type	Recommended Type of Notes for Luminaire Schedule
Bath Bar	Bath bar, incandescent lamps, must be controlled by a vacancy sensor per §150(k)
Ceiling fixture (i.e., for a bathroom application)	Fluorescent surface-mounted ceiling luminaire, with one F32-T8 fluorescent lamp and electronic ballast, meeting the requirements of §150(k)
Fluorescent Recessed Can (i.e., for a kitchen application)	Fluorescent recessed can, with one 26 W pin-based compact fluorescent lamp, meeting the electronic ballast, minimum efficacy, IC, and airtight requirements of §150(k)
Incandescent Recessed Can (i.e., for a Kitchen application)	Incandescent recessed can with a maximum relamping wattage of 75 W, meeting the labeling, IC, and Airtight requirements of §150(k)
Incandescent Recessed Can (i.e., for a Dining Room application)	Incandescent recessed can, meeting the IC, and Airtight requirements of §150(k), and controlled by a dimmer switch meeting the requirements of Sections 119 and 150(k)
Chandelier	Chandelier, controlled by a dimmer switch meeting the requirements of §150(k)
Vacancy Sensor (Manual-on Occupant Sensor)	Vacancy sensor meeting the requirements of Sections 119 and 150(k)